

DFC 350 and 450

Service manual

EN

No. 840121 • rev. 1.4 • 02.09.2015

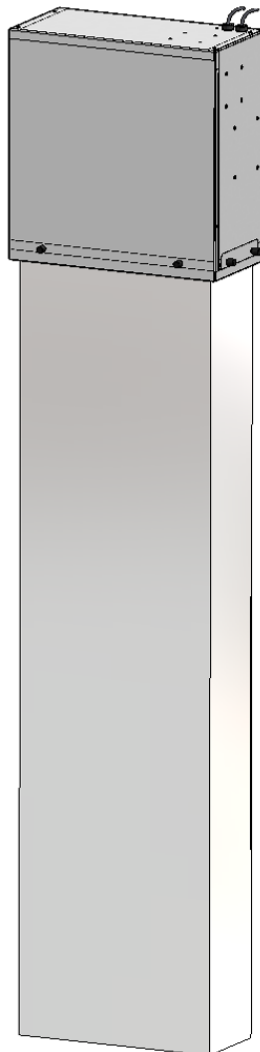

Overview

Introduction

This is the service manual for the Displacement Free Cooling unit DFC 350 & 450.

The DFC 350-450 unit is usually shipped including a control unit. This control unit, TKS 3000A EC, ACUE 3000 or FAC 48, is covered in a separate manual.

Table of content

The Service Manual covers the following main topics:

Topic	See page
General information	4
General principle for DFC units	5
Parts and function	6
How to mount the DFC 350 and DFC 450	7
Technical data DFC 350	10
Technical data DFC 450	11
Technical data DFC 350 and 450	12
Capacity and data diagrams	13
Dimensions	15
Installation alternatives	18
Wiring diagram – ACUE 3000	19
Wiring diagram – TKS 3000A EC	20
Wiring diagram – FAC 48	21
Preventive maintenance	22
Spare parts list	23

General information

Introduction This section provides general information about the unit and this Service Manual.

Target group The target group for this Service Manual is the technicians who install, maintain and repair the unit.

Warning **It is the responsibility of the operator to read and understand this service manual and other information provided and to use the correct operating procedures.**
The product should only be operated by qualified (trained) personnel. Failure to do so can result in personal injury or equipment damage.
 Read the entire manual before the initial start-up of the product. It is important to know the correct operating procedures for the product and all safety precautions to prevent the possibility of property damage and/or personal injury.

Products The Service Manual cover the following products:

Name	Type No.
DFC 350	299763
DFC 450	299745

Copyright Copying of this service manual, or part of it, is not allowed without written permission from Dantherm Air Handling A/S.

Reservations The service manual is subject to changes without notice.

CE-Declaration of Conformity Dantherm Air Handling A/S, Marienlystvej 65, DK7800 Skive hereby declare that the unit are in conformity with the following directives:



2006/95/EG Low Voltage Directive including 93/68/EEC where required
 86/336 EEC EMC Directive including 92/31/EEC and 93/68/EEC
 98/37 EG Machine Directive

The product is manufactured with components which follow the application standards for Low Voltage Directive and in case of norms for EMC in EU countries.

Recycling The unit is designed to last for many years. When the time comes for the unit to be recycled, the unit should be recycled according to national rules and procedures to protect the environment.

General principle for DFC units

General

A DFC (Displacement Free Cooling) unit supplies the cold outdoor air through a diffuser filter with very low velocity. This will make a dune of cold air at the floor and up to a height of 1,6 meter in the shelter. The temperature at the ceiling will be relatively high. The idea is to remove more heat with lower air volume in order to save power consumption of the fan.

This is only possible if a large temperature difference between supply air and air out of the shelter can be achieved.

Efficiency

The efficiency of the DFC unit depends very much on the circulation of the internal air circulation in the telecom equipment and in the shelter. It is therefore very necessary to do a thorough test of the airflows in the shelter before initiating a bigger roll out.

Illustration

The illustration below shows the DFC and some external parts unit mounted in a container:

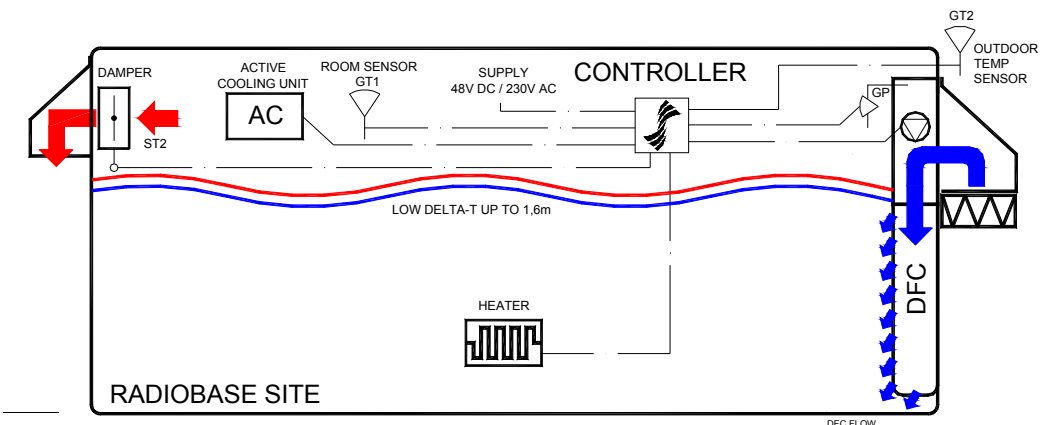

Parts

This table describes the different part (from left to right) in the illustration above:

Part	Description
Outdoor Temp sensor	Measures the outdoor temperature (NTC resistor)
DFC unit	The unit including bag filter and air inlet hood with compact filter
GP	Supply to the unit from power source
Controller	Climate unit controller TKS3000EC, ACUE3000 or others
Heater	External electrical heater
Supply 48V DC/230 V AC	Supply to the controller and the DFC
Room sensor GT1	Measures the indoor temperature (NTC resistor)
Active cooling unit	Existing airconditioner (often split unit)
Damper	Electrical damper allowing warm air to leave the shelter

Continued overleaf

Parts and function

Introduction The DFC units have a simple but very robust design. The parts are shown below.

Illustration This drawing shows the parts of the DFC unit. It includes a fan and a filter guard

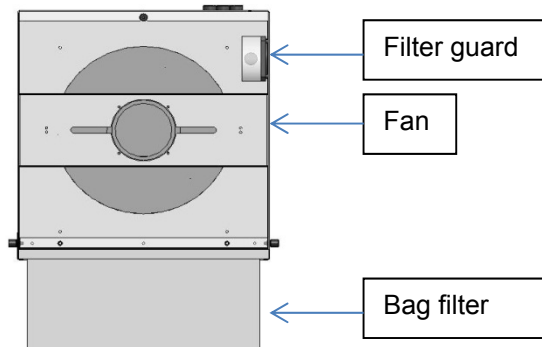

Parts

This table describes the parts in the illustration:

Part	Description
Filter guard	Measures the pressure on both sides of the filter. When the pressure drop exceeds 150 Pascal (factory setting) the built in switch which is connected to the controller will open and cause an alarm.
Fan	The fan is a centrifugal fan either 48 V DC or 230 V AC. See technical data for further information.
Bag filter	The Bag filter is either filter class F5 or F6, see technical data for further information.

How to Mount the DFC 350 or DFC 450

Procedure

Follow these steps to mount the DFC 350 or DFC 450:

Step	Action
1	Make a $\text{Ø}245\text{mm}$ hole in the shelter wall about 1900 mm above the floor.
2	Demount the front cover of the unit by removing the 3 fluted grip knobs.
3	Hold the unit in position and fasten it to the wall with minimum 4 screws.
4	Slide the filter into place and remount the front cover.

DFC 350

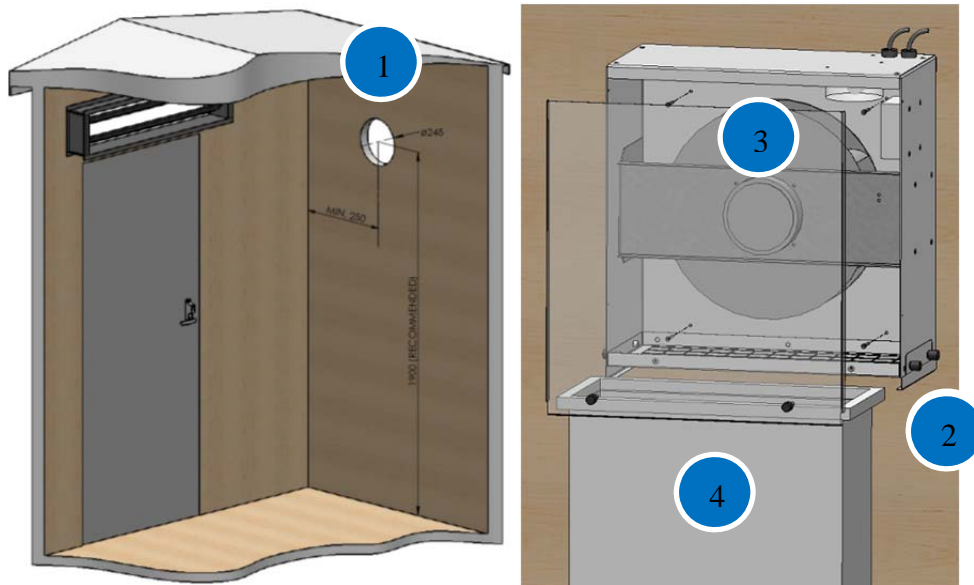

DFC 450

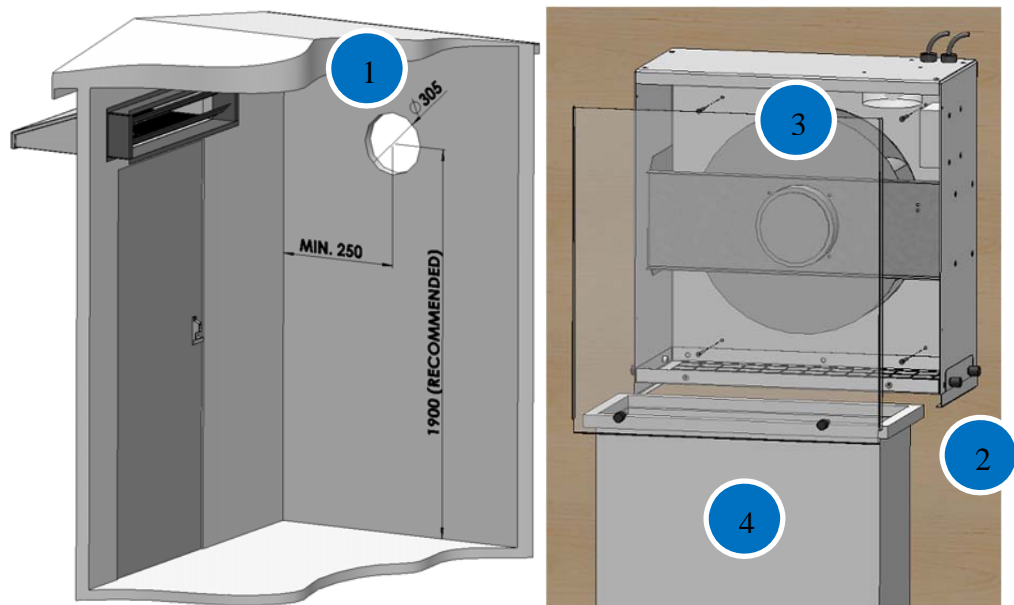

How to Mount the DFC 350 or DFC 450, *continued*

Air inlet hood

Put sealing rubber on the flanges of the hood, hold it in position above the inlet hole and fasten it to the wall.

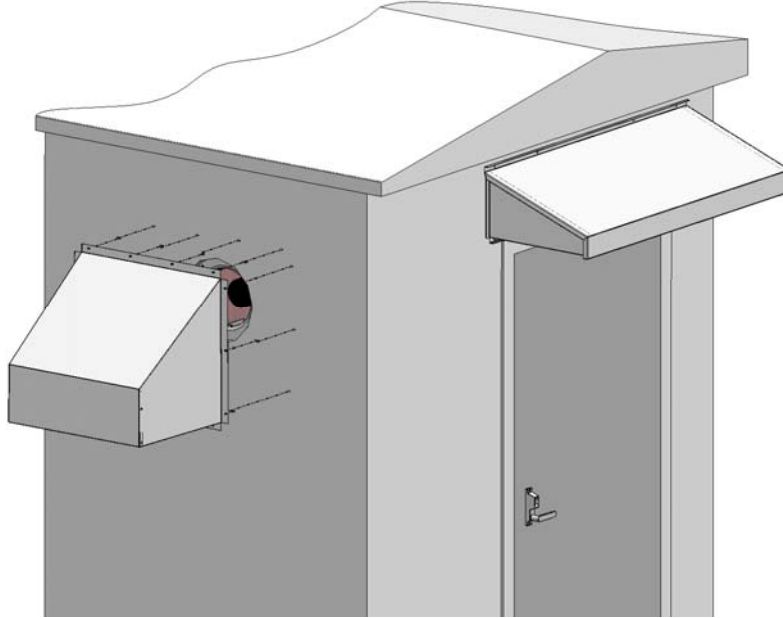

Exhaust damper

Cut out an exhaust opening W: 1000xH: 210mm above the door (when possible). Hold the motorized damper in position and fasten it to the wall.

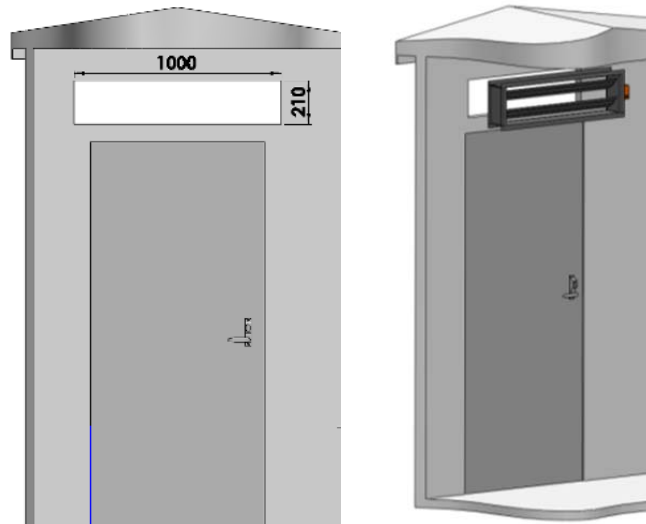

Continued overleaf

How to Mount the DFC 350 or DFC 450, *continued*

Exhaust hood

Put sealing rubber on the flanges of the exhaust hood.
Hold it in position and fasten it to the wall.

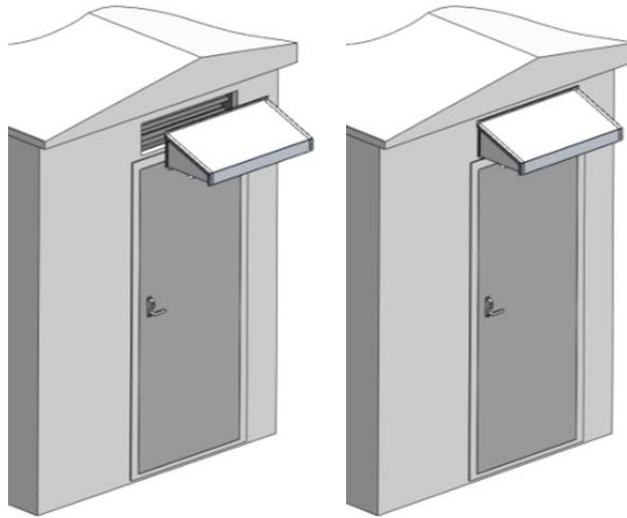

Ground

Connect the DFC 450 to ground by using the nut market with ground symbol.
For more wiring information, please see section *Wiring Diagram*.

Electrical connection

For electrical connection of the unit see the Service Manual for the specific controller that you are using, or see “Wiring Diagram” at the end of this manual.

Technical data DFC 350

Introduction

This Free Cooling unit is very compact, quiet and economic due to the Displacement Free Cooling system. In this product the EC-fan signal is reduced to 5V to get the optimized performance.

Air flow and sound This table shows the technical data for airflow and sound pressure:

Parameter	48V DC	230V AC
Max air flow	514 m ³ /h	514 m ³ /h
Max air flow	143 l/s	143 l/s
Free cooling capacity at $\Delta t=5^{\circ}\text{C}$	3 kW	3 kW
Max power consumption	40 W	35 W
Sound pressure at 5m from shelter	36 dB(A)	34 dB(A)
Sound pressure at 10m from shelter	31 dB(A)	31 dB(A)

Cabinet

This table shows the specifications for the cabinet:

Specification	Designation	DFC 350
Weight	Controller included	10 kg
Metal sheet material	Aluzinc AZ150	0,8-1,5 mm

Fan motor

This table shows the data for the fan motor:

Voltage version	48V DC	230V AC
Voltage nominal	48V DC	230V AC
Current	2,3 A	0,9 A
Max power consumption at standard settings	40 Watt	35 Watt
Speed	1500 rpm	1500 rpm

Filter

This table shows the data for the filter:

Specification	Filter data
Type	Bag filter
Filter Class	F6
Total Area	1,4 m ²
Recommended filter monitor settings	150 Pa

Technical data DFC 350

Air flow and sound This table shows the technical data for airflow and sound pressure:

Voltage version	48V DC	230V AC
Max air flow	1100 m ³ /h	1100 m ³ /h
Max air flow	306 l/s	306 l/s
Free cooling capacity at $\Delta t=5^{\circ}\text{C}$	5 kW	5 kW
Max power consumption	40 W	61 W
Sound pressure at 5m from shelter	36 dB(A)	34 dB(A)
Sound pressure at 10m from shelter	31 dB(A)	31 dB(A)

Cabinet

Data and dimensions of the cabinet are shown in the following table:

Specification	Designation	DFC 450
Weight	Controller excluded	13 kg
Metal sheet material	Aluzinc AZ150	0,8-1,5 mm

Fan motor

Data of the fan motor is shown in the following table:

Voltage version	48V DC	230V AC
Voltage nominal	48V DC	230V AC
Current	2,3 A	1,1 A
Max power consumption	40 W	54 W
Speed	1200 rpm	1200 rpm

Filter

In the table below the data of the filter are specified:

Specification	Filter data	Filter data
Type	Bag filter	
Filter Class	F5	F6
Total Area	2 m ²	
Recommend filter monitor setting	100 Pa	150 Pa

Electrical heater, This table shows the voltage and power consumption of the electrical heater (optional):

Specification	Value
Power, Voltage	1300 W, 230 V AC

Technical data DFC 350 and 450

Controls

The table below show the specification for the 2 controllers for the DFC unit:

Specification	48V DC		230V DC
	Enclosure IP65	DIN rail mounting	Enclosure IP65
Standard control units (See separate manuals)	ACUE 3000		TKS 3000 EC
Special control units (See separate manuals)		FAC 48	
Indoor temperature sensor	RG-TD5	RG-TD5	RG-TD5
Outdoor temperature sensor	UG-TD5 (optional)	UG-TD5 (optional)	UG-TD5 (optional)
Filter monitor	JDW5 (optional)	JDW5 (optional)	JDW5 (optional)

Capacity and data diagrams

Performance

The diagram below shows data for DFC 350:

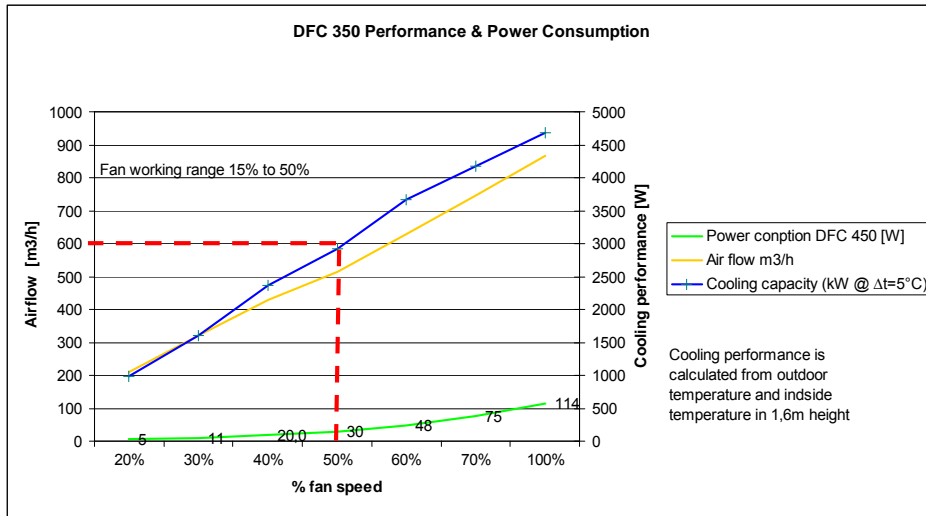

Airflow & Pressure drop The diagram below shows data for DFC 350:

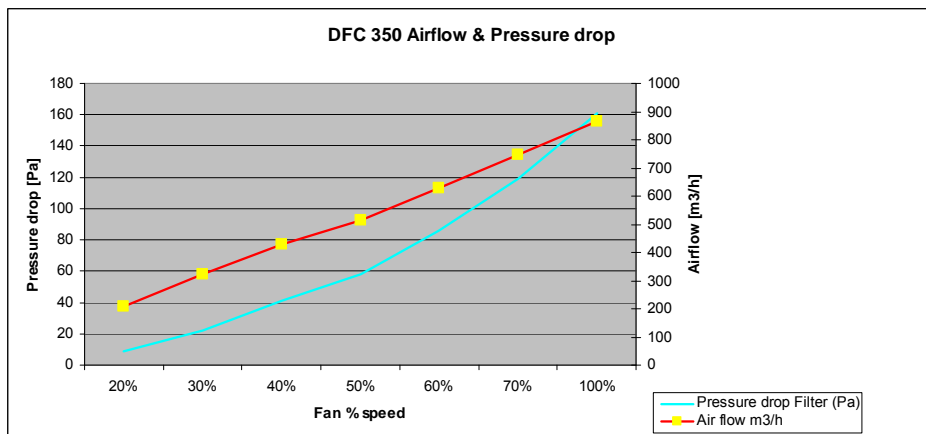

Performance

The diagram below shows data for DFC 450:

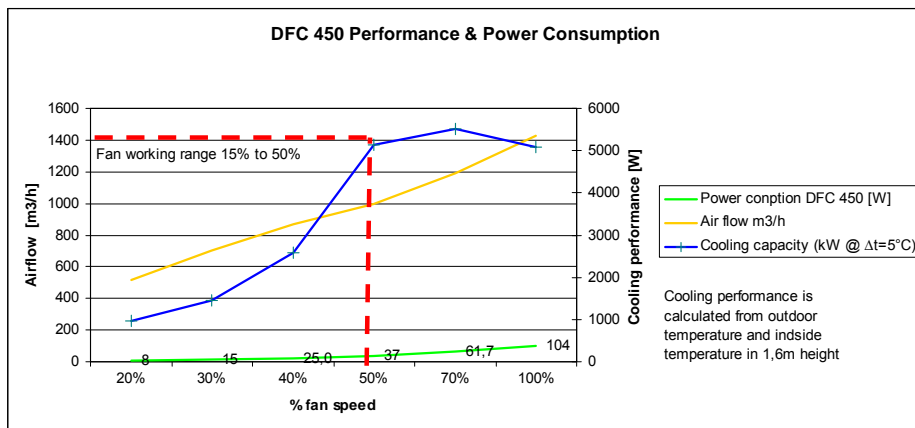

Continued overleaf

Capacity and data diagrams, *continued*

Airflow & Pressure drop The diagram below shows data for DFC 450:
drop

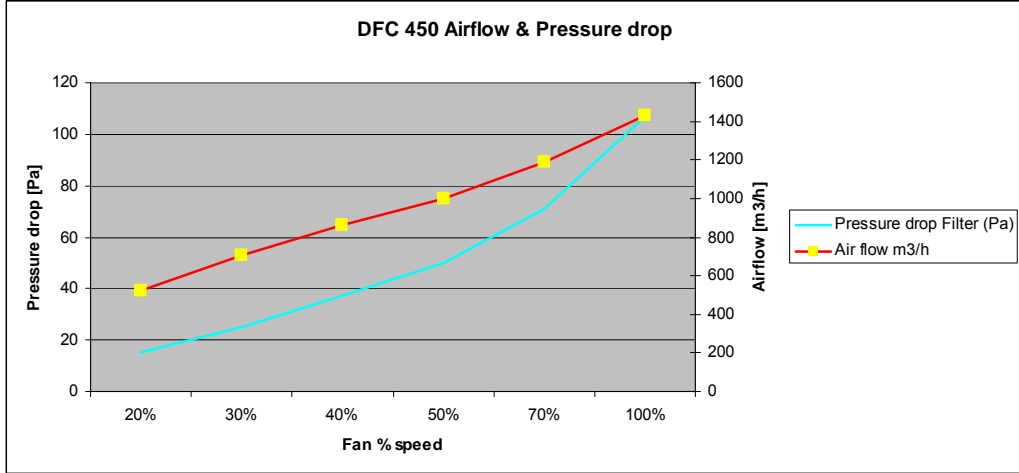

Dimensions

Illustration DFC 350 The drawings below illustrate the dimensions of the DFC 350.

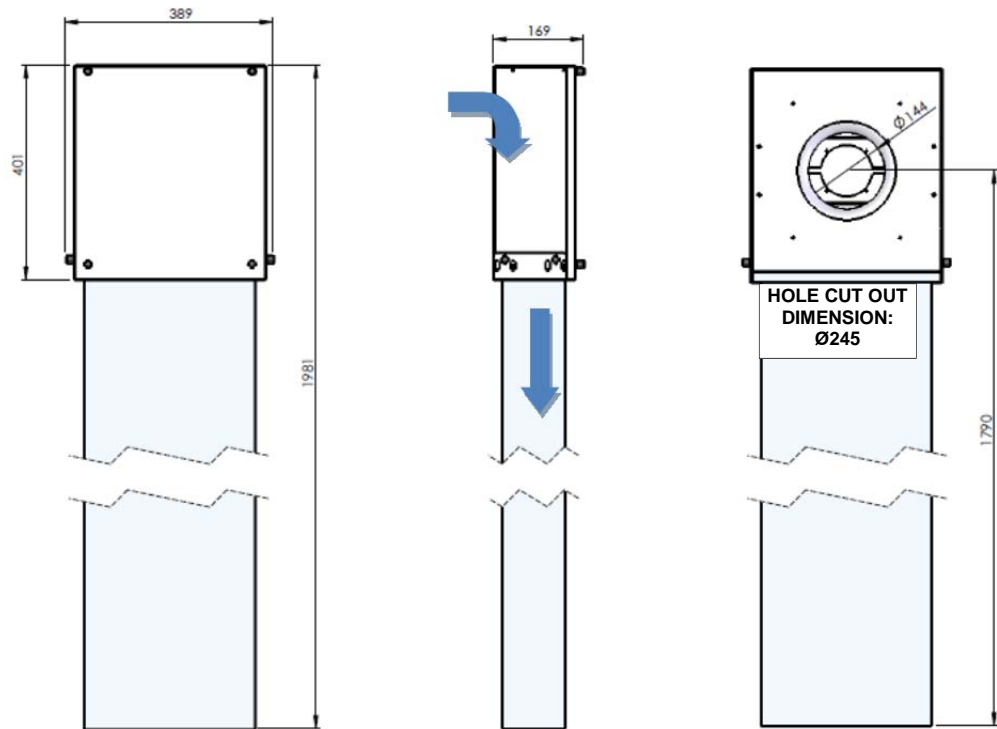

Continued overleaf

Dimensions, *continued*

Illustration DFC 450 The drawings below illustrate the dimensions of the DFC 450.

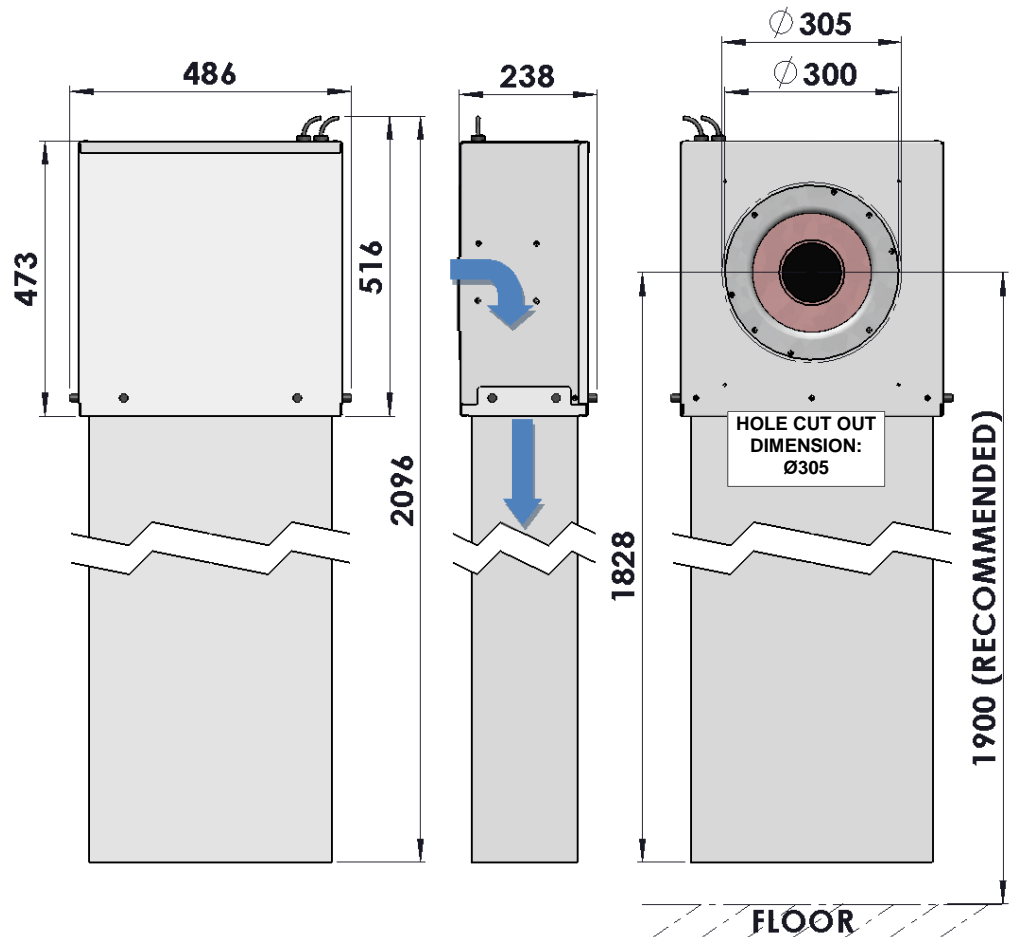

Continued overleaf

Dimensions, *continued*

External accessories

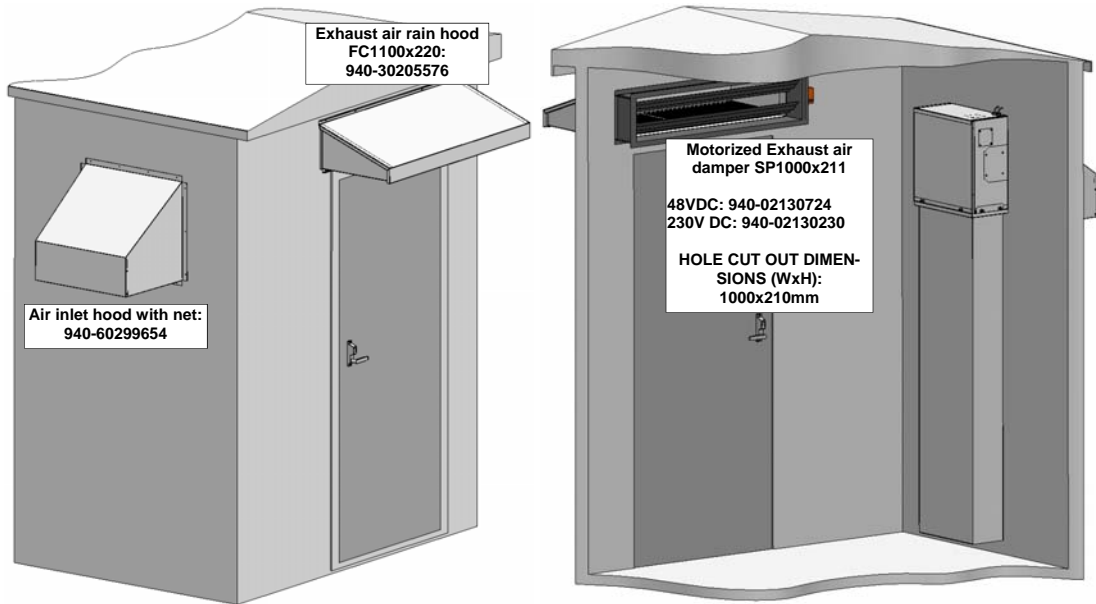

Installation alternatives

Introduction

The pictures below shows the three ways the Displacement Free Cooling unit can be mounted and still make filter exchange easy. There are three different lids, of which only one should be opened to take out and replace the bag filter.

Front service



Left and right service

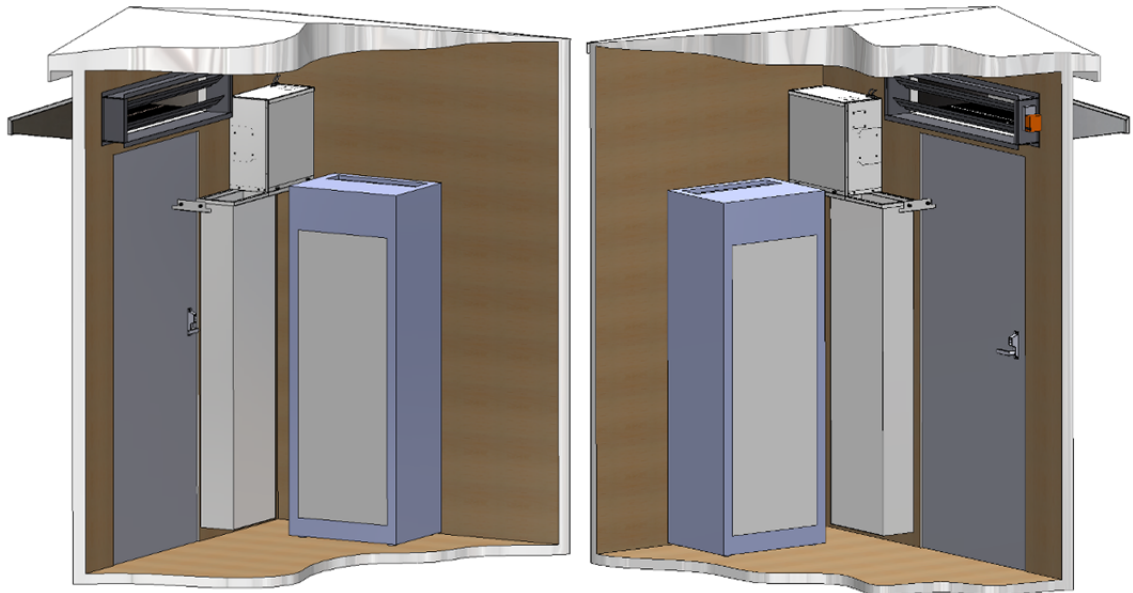

Wiring diagram – ACUE 3000

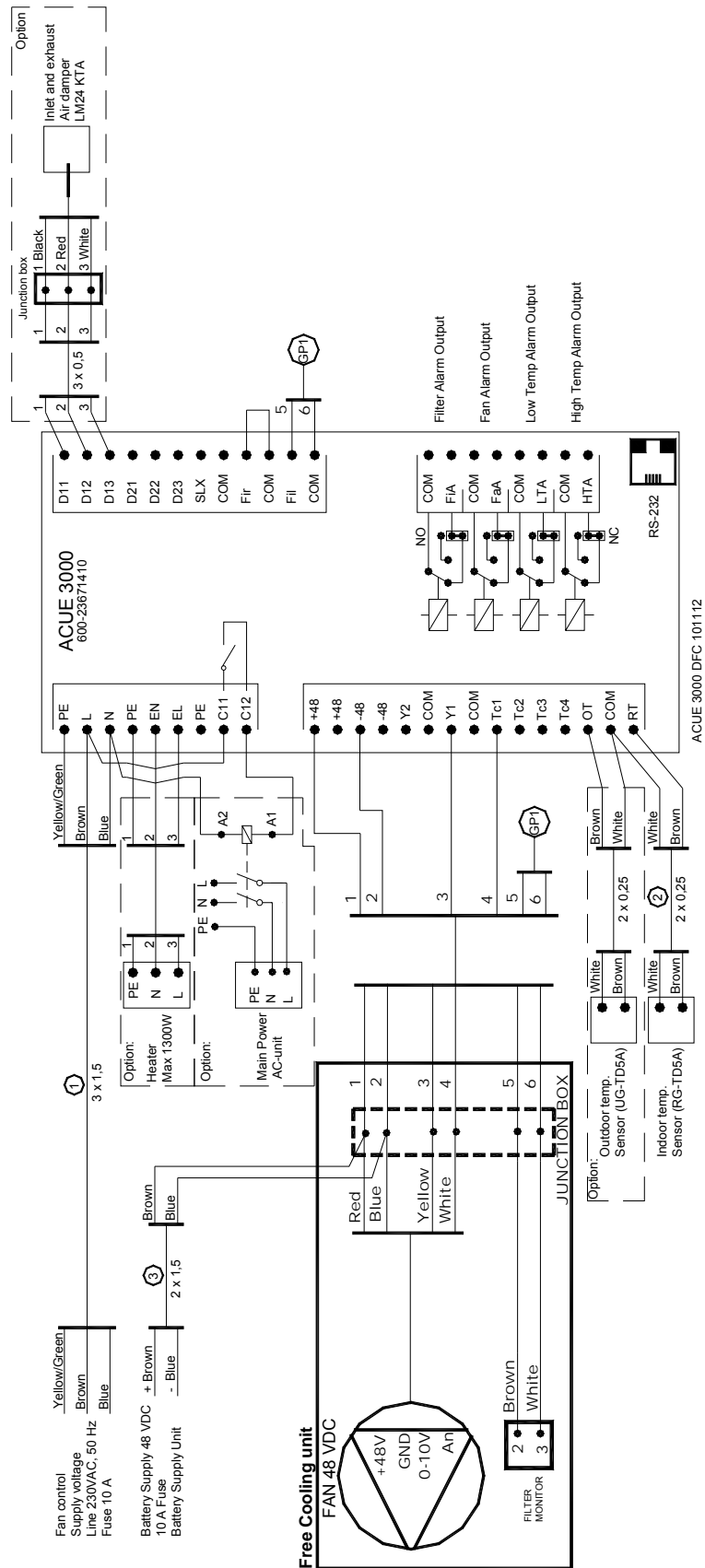

Wiring diagram – TKS 3000A EC

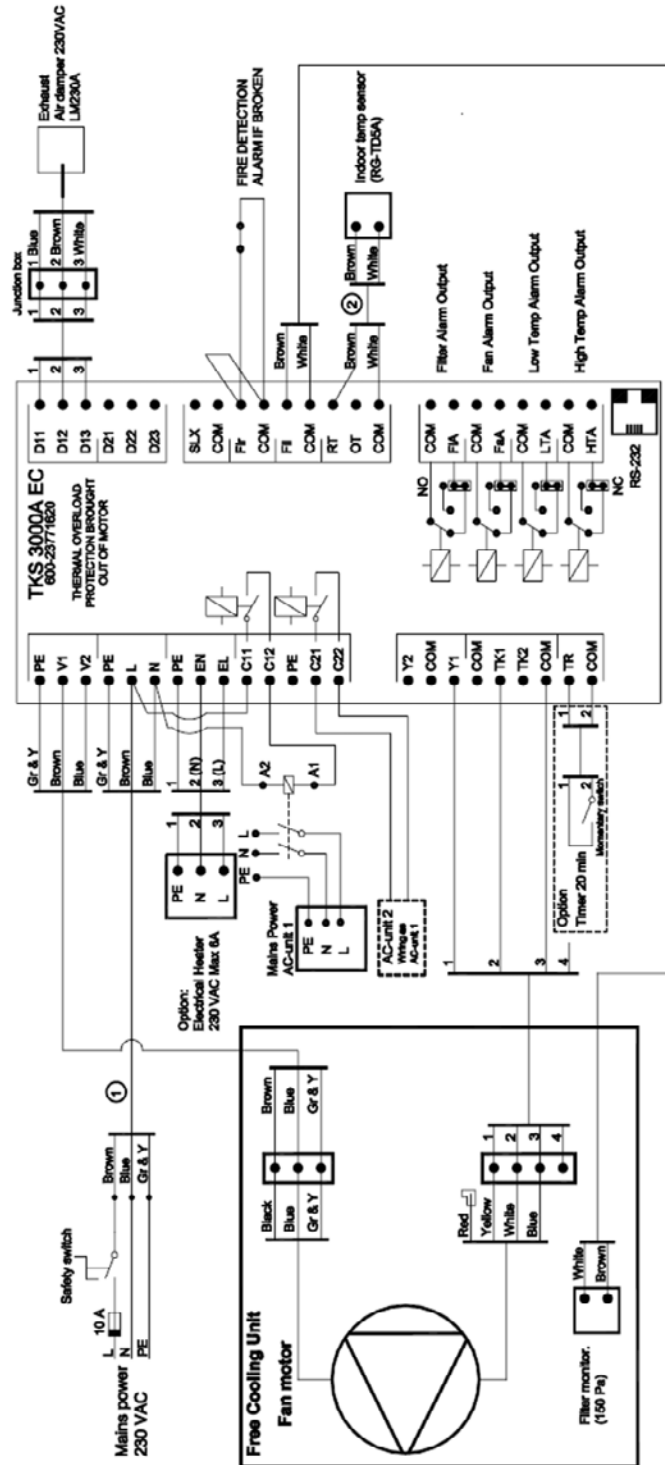

File: TKS 3000A EC DFC 110404

Wiring diagram – FAC 48

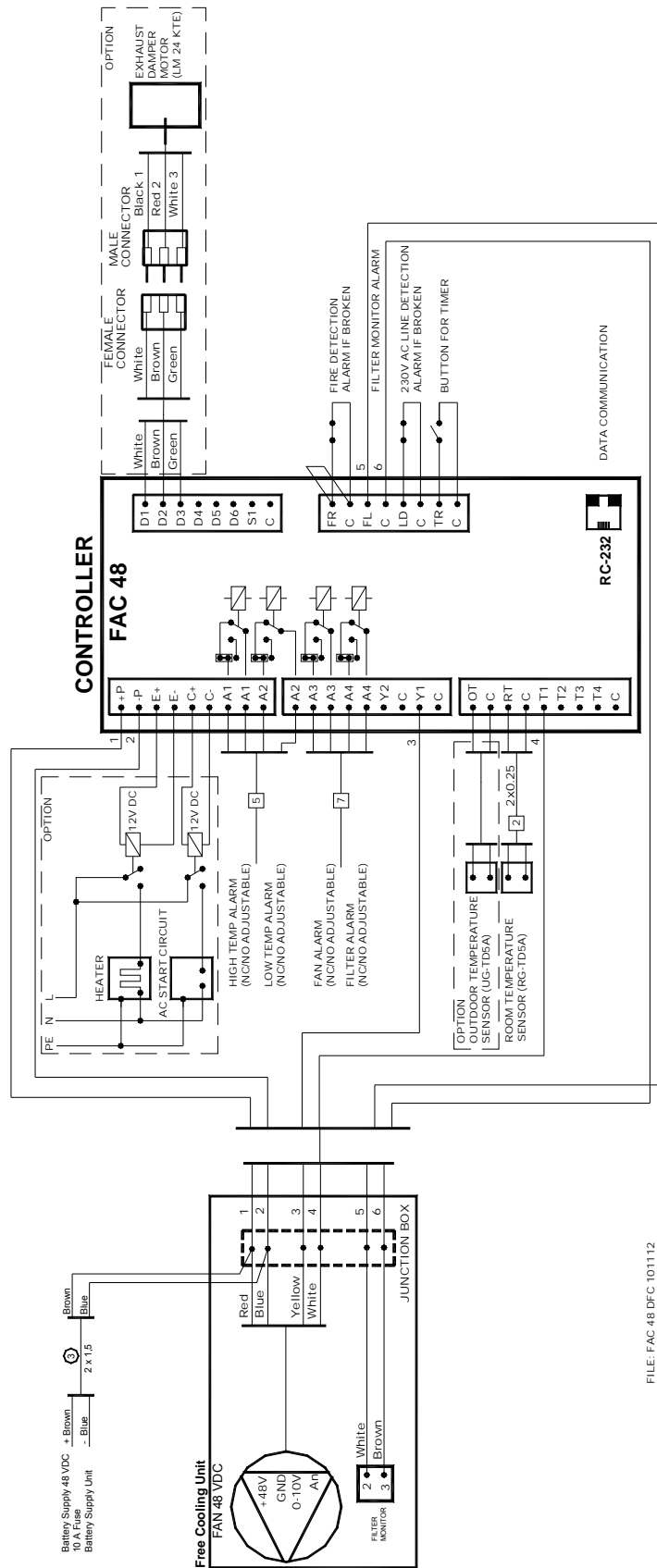



FILE: FAC 48 DFC 101112

Preventive maintenance

Introduction The unit needs preventive maintenance with specific intervals to avoid breakdown or inefficient operation. It is important to notice that interval between maintenance can vary depending on the specific environment.

Caution! Switch off both the DC and AC supply before working on the unit!
Make sure that all work has been performed before switching on the power again.

Service function The control unit has a service function to ensure better indoor climate for 20 minutes during the presence of service technicians. To activate the service function, push one step up from the main menu to find "Timer". Now press "Enter". The control unit will now count down from 20 minutes and after that go back to normal operation.

"Timer"  

Interval Dantherm Air Handling AB recommends that intervals between preventive maintenance do not exceed 1 year. It is also our recommendation that the site and unit is examined closely during the first preventive maintenance to determine whether the interval is too long. We recommend that preventive maintenance visits are carried out during spring.

Condition for warranty The factory warranty is only valid if documented preventive maintenance has been carried out with an interval of maximum 1 year. The documentation should be in form of a written log.

Leaving the site Before leaving the site, make sure there are no alarms!

Recommended approach Follow these steps to carry out preventive maintenance on the unit:

Step	Action
1	Make sure that the power to the unit is safely switched off.
2	Remove the worn-out filter and clean the unit carefully.
3	Clean the dampers with regards to function and tightness.
4	Clean the fan and check that the mounting is OK.
5	Check and clean the air intake and exhaust accessories.
6	Insert the new filter carefully into the unit.
7	Close the unit and make sure that the service is completed correctly.
8	Turn on the power to the unit.
9	Run the Self test according to the separate manual for the controller.

Spare parts list

Spare parts DFC 350 only

This table shows the spare parts for **DFC 350**:

Spare part	Type	Part number
Bag filter	Filter class F5	299821
Bag filter	Filter class F6	067335
Fan – 48V DC	EC, Centrifugal fan, 48V DC	067738
Fan – 230V AC	EC, Centrifugal fan, 230V AC	840060

Spare parts DFC 450 only

This table shows the spare parts for **DFC 450**:

Spare part	Type	Part number
Bag filter	Filter class F5	299749
Bag filter	Filter class F6	840058
Fan – 48V DC	EC, Centrifugal fan, 48V DC	067739
Fan – 230V AC	EC, Centrifugal fan, 230V AC	840061

Control parts

This table shows the various control parts, sensors and filter monitor for both the DFC 350 and DFC 450. Check the label on the controller for identification:

Spare part	Type	Part number
Control Unit 48V	ACUE 3000 – 48V DC	840012
Control Unit 230V Std. A03	TKS 3000A EC – 230V AC	840014
Control Unit 230V En,Fr,NL	TKS 3000A EC – 230V AC	090632
Control Unit 230V – EN,FR,NL w/out min. speed	TKS 3000A EC – 230V AC	096333
Control Unit 230V – Std – A05	TKS 3000A EC – 230V AC	096336
Indoor temp. sensor	RG-TD5A	840017
Alt. Indoor temp. sensor	SG-TD5A, 5m cable	840018
Outdoor temp. sensor	UG-TD5A	840019
Filter monitor		840020

Other parts

This table shows the available damper actuators and heater:

Spare part	Type	Part number
Damper actuator for 48V controller	LM24A KTE	840021
Damper actuator for 230V controller	LM230A	840022
External heater	1300/550W, 230V	840023

accessories	17
air flow.....	10; 11
airflow.....	5
area.....	10
bag filter	6
cabinet	10
conformity.....	4
control unit.....	12
cooling capacity.....	10; 11
copyright.....	4
dimension.....	15
DIN rail	12
directive.....	4
efficiency	5
electrical connection.....	9
enclosure.....	12
exhaust.....	8
filter class	6; 11
filter Class	10
filter guard	6
filter monitor	12
front cover	7
function.....	6
ground	9
hole	7
indoor temperature sensor	12
installation	18

interval.....	22
maintenance	22
motorized damper.....	8
mount	7
outdoor temperature sensor	12
performance	13
power consumption	10; 11
pressure drop	13
preventive.....	22
principle	5
recycling	4
sealing	8; 9
service	18
service function timer.....	22
shelter.....	5
sound pressure.....	10; 11
spare parts.....	23
speed.....	10; 11
table of content.....	3
voltage.....	10; 11
warning.....	4
warranty.....	22
weight	10; 11
wiring diagram – ACUE 3000	19
wiring diagram – FAC 48	21
wiring diagram – TKS 3000A EC	20

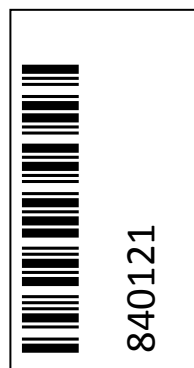

Dantherm Air Handling A/S

Marienlystvej 65

7800 Skive

Denmark

www.dantherm.com

service@dantherm.com